

SCHUMANN'S SECOND REPLAT

EYOTA, MINNESOTA

SURVEYOR'S CERTIFICATE

STATE OF MINNESOTA)
COUNTY OF OLMSTED) S.S.

I DO HEREBY CERTIFY THAT I HAVE SURVEYED AND PLATTED THE PROPERTY DESCRIBED ON THIS PLAT AS "SCHUMANN'S SECOND REPLAT" THAT THIS IS A CORRECT REPRESENTATION OF SAID SURVEY; THAT ALL DISTANCES ARE CORRECTLY SHOWN ON SAID PLAT IN FEET AND DECIMALS OF A FOOT; THAT ALL MONUMENTS HAVE BEEN CORRECTLY PLACED IN THE GROUND AS SHOWN ON THE PLAT; THAT THE OUTSIDE BOUNDARY LINES ARE CORRECTLY DESIGNATED ON THE PLAT; THAT THERE ARE NO WET LANDS OR PUBLIC HIGHWAYS TO BE DESIGNATED ON SAID PLAT OTHER THAN AS SHOWN THEREON; AND THAT SAID PLAT HAS BEEN PREVIOUSLY PLATTED AS PARTS OF BLOCKS A, B, C AND D OF SUBURBAN ADDITION TO THE VILLAGE OF EYOTA, AND LOT 4 OF BLOCK 4 AND LOT 3 OF BLOCK 5 OF SCHUMANN'S FRIENDLY REPLAT OF BLOCKS B AND C SUBURBAN ADDITION.

K.M. McElhin 1613
SURVEYOR MINNESOTA REGISTRATION NUMBER

STATE OF MINNESOTA)
COUNTY OF OLMSTED) S.S.

THE ABOVE SURVEYOR'S CERTIFICATE WAS SUBSCRIBED AND SWORN TO BEFORE ME, A NOTARY PUBLIC WITHIN AND FOR SAID COUNTY AND STATE ON THIS 21 DAY OF February 1973 A.D.

Howard E. Hunt
Notary Public, Olmsted County, Minn.
My Commission Expires Dec. 9, 1978
NOTARY PUBLIC, OLMSTED COUNTY, MINNESOTA

COUNTY SURVEYOR'S CERTIFICATE OF APPROVAL

I CERTIFY THAT THIS PLAT HAS BEEN CHECKED MATHEMATICALLY AND THAT THE PLAT CONFORMS TO THE APPLICABLE PLATTING LAWS.

APPROVED THIS 14 DAY OF March 1973 A.D.

BY Roger W. Brand
OLMSTED COUNTY SURVEYOR

STATE OF MINNESOTA)
COUNTY OF OLMSTED) S.S.
VILLAGE OF EYOTA)

I, ROBERT LOVEJOY, VILLAGE CLERK IN AND FOR SAID VILLAGE OF EYOTA, DO HEREBY CERTIFY THAT ON THE 7th DAY OF FEBRUARY 1973 A.D. THE ACCOMPANYING PLAT WAS DULY APPROVED BY THE COMMON COUNCIL OF THE VILLAGE OF EYOTA, IN TESTIMONY WHEREOF, I HAVE HERETO SIGNED MY NAME AND AFFIXED THE SEAL OF SAID VILLAGE OF EYOTA THIS 7th DAY OF MARCH 1973 A.D.

Robert Lovejoy
VILLAGE CLERK

NO DELINQUENT TAXES DUE AND TRANSFER ENTERED THIS 15th DAY OF March 1973 A.D.

Ross Brauning
COUNTY AUDITOR

345524

STATE OF MINNESOTA)
COUNTY OF OLMSTED) S.S.

FILED FOR RECORD THIS 15th DAY OF March 1973 A.D., AT 11 1/2

O'CLOCK A.M. IN BOOK _____ OF PLATS ON PAGE _____

INSTRUMENT NUMBER 345524

Wm. J. Collins
REGISTER OF DEEDS

UTILITY EASEMENT DEFINED:

AN UNOBSTRUCTED EASEMENT FOR THE CONSTRUCTION AND MAINTENANCE OF ALL NECESSARY OVERHEAD, UNDERGROUND OR SURFACE, PRIVATE AND PUBLIC UTILITIES, INCLUDING RIGHTS TO CONDUCT DRAINAGE AND TRIMMING ON SAID EASEMENT.

CURVE	DELTA	DEGREE	LENGTH	TANGENT	RADIUS
A-O (BOUNDARY)	10°44'30"	11°13'28"	95.70	47.99	510.46
A-Q	11°32'05"	12°00'00"	96.11	48.22	477.46
A-I	12°26'54"	12°53'28"	96.57	48.47	444.46

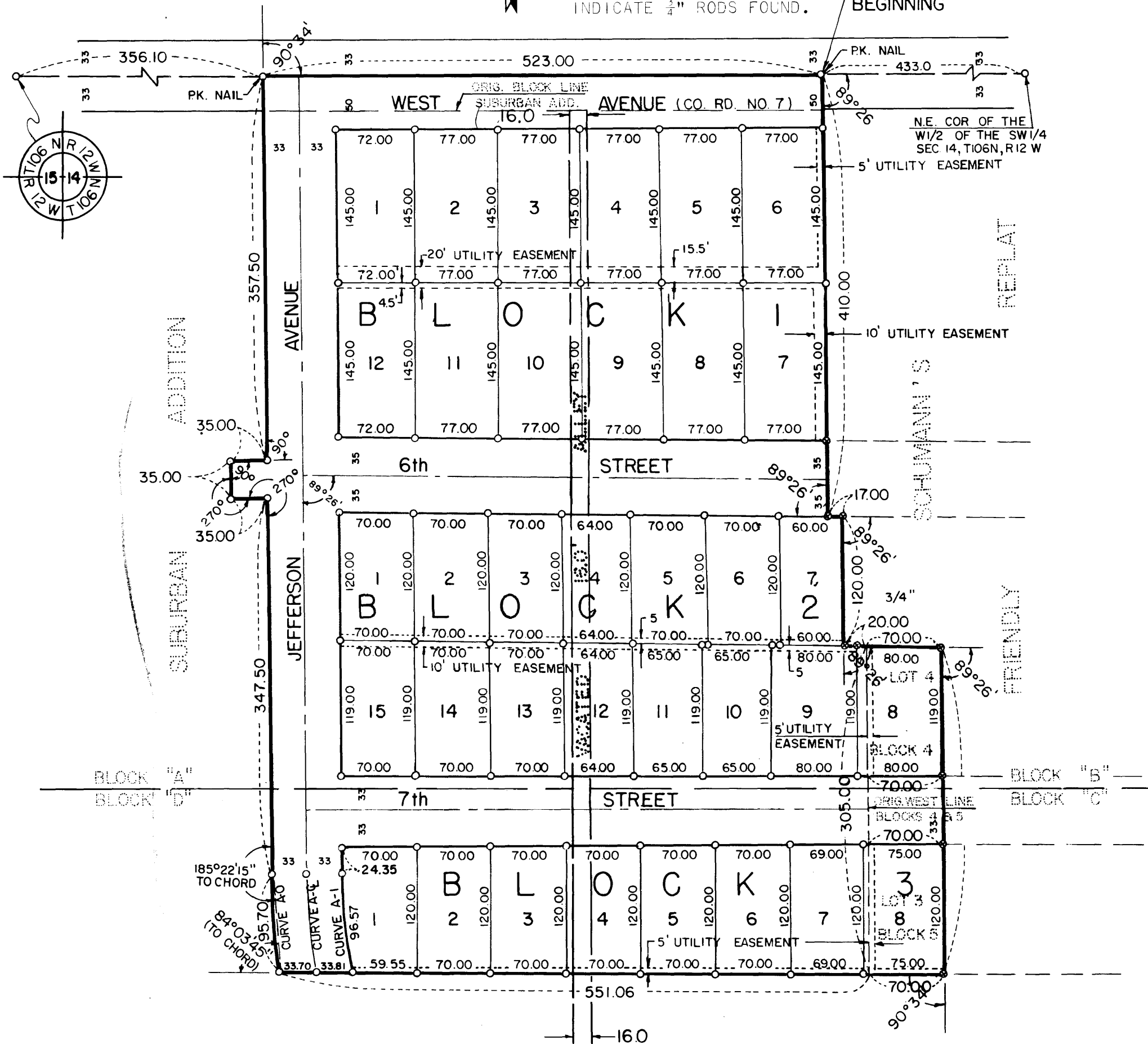
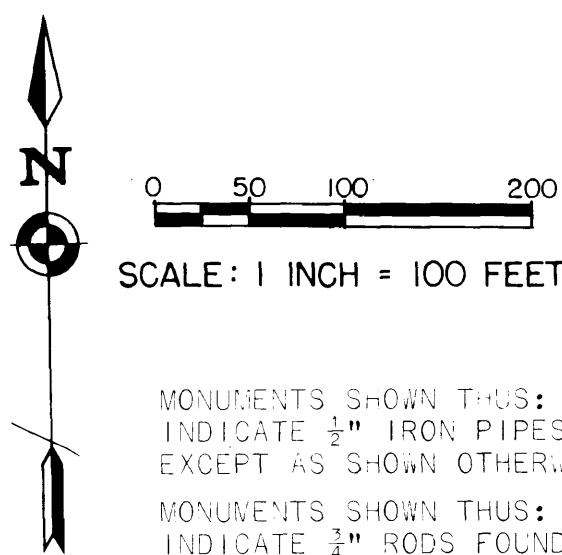

OWNERS DEDICATION:

KNOW ALL MEN BY THESE PRESENTS: THAT ALFRED O. SCHUMANN AND HELEN M. SCHUMANN, HIS WIFE, AND GERALD A. LOVEJOY AND CAROL A. LOVEJOY, HIS WIFE, AND DAVID K. HARDTKE AND ALICE M. HARDTKE, HIS WIFE, FARMERS STATE BANK OF EYOTA, MINNESOTA, AND ROCHESTER SAVINGS AND LOAN ASSOCIATION, OWNERS AND PROPRIETORS OF THE FOLLOWING DESCRIBED PROPERTY SITUATED IN THE VILLAGE OF EYOTA STATE OF MINNESOTA, TO WIT:

A PART OF BLOCKS A, B, C AND D OF SUBURBAN ADDITION TO THE VILLAGE OF EYOTA, MINNESOTA, BEING LOCATED IN THE WEST ONE-HALF (1/2) OF THE SOUTHWEST QUARTER OF SECTION 14, TOWNSHIP 106 NORTH, RANGE 12 WEST AND MORE PARTICULARLY DESCRIBED AS FOLLOWS:

COMMENCING AT THE NORTHEAST CORNER OF THE WEST ONE-HALF (1/2) OF SAID QUARTER SECTION; THENCE WEST ALONG THE NORTH LINE OF SAID QUARTER SECTION A DISTANCE OF 433.00 FEET TO THE NORTHWEST CORNER OF SCHUMANN'S FRIENDLY REPLAT OF BLOCKS B AND C OF SAID SUBURBAN ADDITION FOR A POINT OF BEGINNING; THENCE SOUTH AT A DEFLECTION ANGLE OF 90 DEGREES 34 MINUTES TO THE LEFT ALONG THE WEST LINE OF SAID REPLAT A DISTANCE OF 410.00 FEET; THENCE EAST AT A DEFLECTION ANGLE OF 89 DEGREES 26 MINUTES TO THE LEFT A DISTANCE OF 17.00 FEET; THENCE SOUTH AT A DEFLECTION ANGLE OF 89 DEGREES 26 MINUTES TO THE RIGHT A DISTANCE OF 120.00 FEET; THENCE EAST AT A DEFLECTION ANGLE OF 89 DEGREES 26 MINUTES TO THE LEFT A DISTANCE OF 20.00 FEET; THENCE SOUTH AT A DEFLECTION ANGLE OF 89 DEGREES 26 MINUTES TO THE RIGHT A DISTANCE OF 305.00 FEET TO THE SOUTHWEST CORNER OF SAID REPLAT; THENCE WEST AT A DEFLECTION ANGLE OF 90 DEGREES 34 MINUTES TO THE RIGHT A DISTANCE OF 551.06 FEET TO A POINT ON A CURVE WHOSE RADIUS IS 510.46 FEET AND WHOSE CHORD IS AT A DEFLECTION ANGLE OF 84 DEGREES 03 MINUTES 45 SECONDS TO THE RIGHT FROM THE PREVIOUS DESCRIBED COURSE; THENCE NORTHERLY, DEFLECTING TO THE RIGHT ALONG SAID CURVE, A DISTANCE OF 95.70 FEET TO THE POINT OF TANGENT OF SAID CURVE; THENCE NORTH, TANGENT TO SAID CURVE A DISTANCE OF 347.50 FEET; THENCE WEST AT RIGHT ANGLES A DISTANCE OF 35.00 FEET; THENCE NORTH AT RIGHT ANGLES A DISTANCE OF 35.00 FEET; THENCE EAST AT RIGHT ANGLES A DISTANCE OF 35.00 FEET; THENCE NORTH AT RIGHT ANGLES A DISTANCE OF 357.50 FEET TO A POINT IN THE NORTH LINE OF SAID QUARTER SECTION; THENCE EAST ALONG THE NORTH LINE OF SAID QUARTER SECTION A DISTANCE OF 523.00 FEET TO THE POINT OF BEGINNING.

ALSO LOT 4 OF BLOCK 4 AND LOT 3 OF BLOCK 5 OF SCHUMANN'S FRIENDLY REPLAT OF BLOCKS B AND C OF SUBURBAN ADDITION TO THE VILLAGE OF EYOTA.

HAVE CAUSED THE SAME TO BE SURVEYED AND PLATTED AS "SCHUMANN'S SECOND REPLAT" AND DO HEREBY DONATE AND GRANT THE EASEMENTS DEFINED THEREON. IN WITNESS WHEREOF WE HAVE HERETO SET OUR HANDS THIS 9th DAY OF March 1973 A.D.

IN THE PRESENCE OF:
Alfred O. Schumann AND L. Wiesendick ALFRED O. SCHUMANN
Helen M. Schumann AND L. Wiesendick HELEN M. SCHUMANN
Gerald A. Lovejoy AND L. Wiesendick GERALD A. LOVEJOY
Carol A. Lovejoy AND L. Wiesendick CAROL A. LOVEJOY
David K. Hardtke AND L. Wiesendick DAVID K. HARDTKE
Alice M. Hardtke AND L. Wiesendick ALICE M. HARDTKE

STATE OF MINNESOTA)
COUNTY OF OLMSTED) S.S.

ON THIS 9th DAY OF MARCH 1973 A.D., BEFORE ME A NOTARY PUBLIC IN AND FOR SAID COUNTY, PERSONALLY APPEARED ALFRED O. SCHUMANN AND HELEN M. SCHUMANN, HIS WIFE, AND GERALD A. LOVEJOY AND CAROL A. LOVEJOY, HIS WIFE, AND DAVID K. HARDTKE AND ALICE M. HARDTKE, HIS WIFE, TO ME KNOWN TO BE THE PERSONS DESCRIBED IN AND WHO EXECUTED THE SAME AS THEIR FREE ACT AND DEED.

MY COMMISSION EXPIRES L. Wiesendick, Notary Public, Olmsted Co., Minn. A.D.
My Commission Expires July 15, 1970

L. Wiesendick
NOTARY PUBLIC OLMSTED COUNTY, MINNESOTA

IN THE PRESENCE OF: ROCHESTER SAVINGS AND LOAN ASSOCIATION (MORTGAGEE FOR DAVID K. HARDTKE AND ALICE M. HARDTKE)

Dolores J. Dobson AND Wm. E. Shedd WILLIAM E. SHEDD, PRESIDENT
Dolores J. Dobson AND Herbert A. Gerlitz HERBERT A. GERLITZ, VICE-PRES.

STATE OF MINNESOTA)
COUNTY OF OLMSTED) S.S.

ON THIS 15th DAY OF March 1973 A.D., BEFORE ME A NOTARY PUBLIC IN AND FOR SAID COUNTY, PERSONALLY APPEARED WILLIAM E. SHEDD AND HERBERT A. GERLITZ TO ME PERSONALLY KNOWN, WHO BEING EACH DULY SWORN, DID SAY THAT THEY ARE RESPECTIVELY PRESIDENT AND VICE-PRESIDENT OF THE ROCHESTER SAVING AND LOAN ASSOCIATION AND THAT THE SEAL AFFIXED TO THIS INSTRUMENT IS THE CORPORATE SEAL OF SAID CORPORATION, AND THAT SAID INSTRUMENT WAS SIGNED IN ITS BEHALF BY AUTHORITY OF ITS MEMBERS, AND SAID WILLIAM E. SHEDD AND HERBERT A. GERLITZ ACKNOWLEDGED SAID INSTRUMENT TO BE THE FREE ACT AND DEED OF SAID CORPORATION.

MY COMMISSION EXPIRES _____ A.D.

Wm. E. Shedd
NOTARY PUBLIC - MINNESOTA
OLMSTED COUNTY
My Commission Expires Jan. 29, 1977

IN THE PRESENCE OF: FARMERS STATE BANK OF EYOTA, MINNESOTA (MORTGAGEE FOR GERALD A. LOVEJOY AND CAROL A. LOVEJOY)

Paul L. Hammel AND L. Wiesendick PAUL L. HAMMEL, VICE-PRES.
R.J. Reich AND L. Wiesendick R.J. REICH, CASHIER

STATE OF MINNESOTA)
COUNTY OF OLMSTED) S.S.

ON THIS 9th DAY OF MARCH 1973 A.D., BEFORE ME A NOTARY PUBLIC IN AND FOR SAID COUNTY, PERSONALLY APPEARED PAUL L. HAMMEL AND R.J. REICH, TO ME PERSONALLY KNOWN, BEING EACH BY ME DULY SWORN, DID SAY THAT THEY ARE RESPECTIVELY VICE-PRESIDENT AND CASHIER OF THE FARMERS STATE BANK, A CORPORATION, AND THAT THE SEAL AFFIXED TO THIS INSTRUMENT IS THE CORPORATE SEAL OF SAID CORPORATION, AND THAT SAID INSTRUMENT IS SIGNED AND SEALED IN ITS BEHALF BY AUTHORITY OF ITS MEMBERS, AND SAID PAUL L. HAMMEL AND R.J. REICH ACKNOWLEDGED SAID INSTRUMENT TO BE THE FREE ACT AND DEED OF SAID CORPORATION,

MY COMMISSION EXPIRES L. Wiesendick, Notary Public, Olmsted Co., Minn. A.D.
My Commission Expires July 15, 1970

L. Wiesendick
NOTARY PUBLIC, OLMSTED COUNTY, MINNESOTA

OFFICIAL PLAT