

COMMON INTEREST COMMUNITY NUMBER 305

A CONDOMINIUM, WEST 19 BUSINESS PLAZA

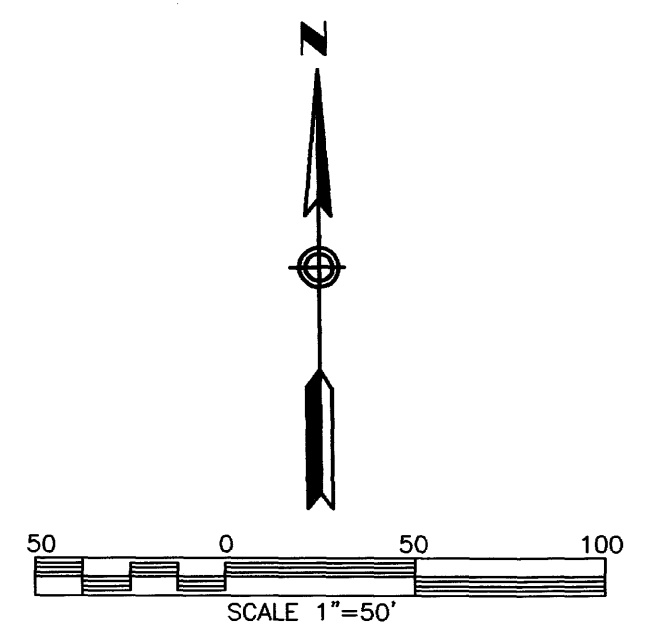
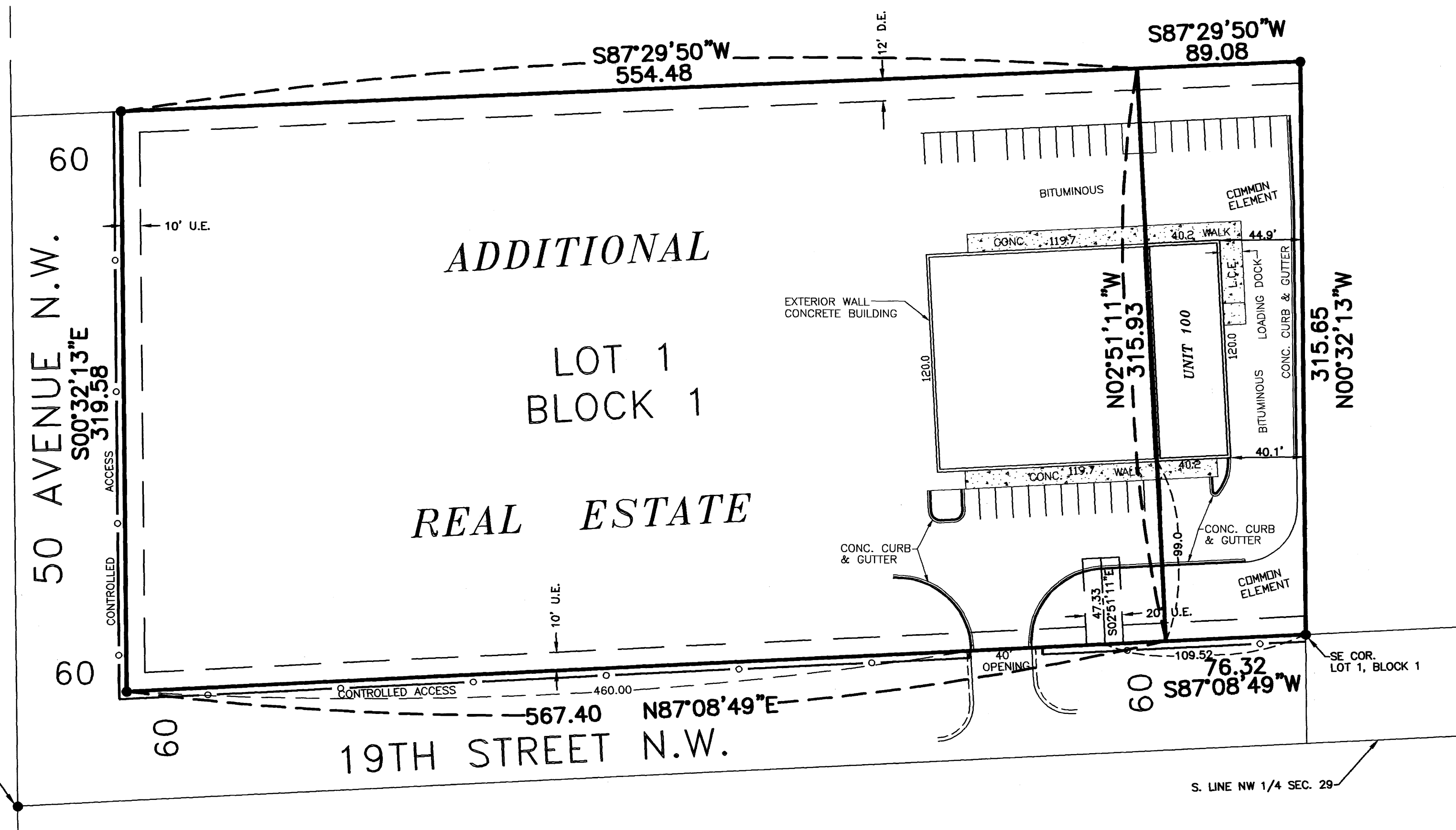

This Common Interest Community Plat is part of the Declaration recorded as

Document No. A-1090966

on this 2ND day of February, 2006.

W. Mark Krupski, Assistant
Director of Property Records and Licensing

Wendy von Wald
Deputy

B.M. ELEV. 1047.08
TOP HYDRANT NUT @ E. SIDE OF
ENTRANCE TO PROPERTY

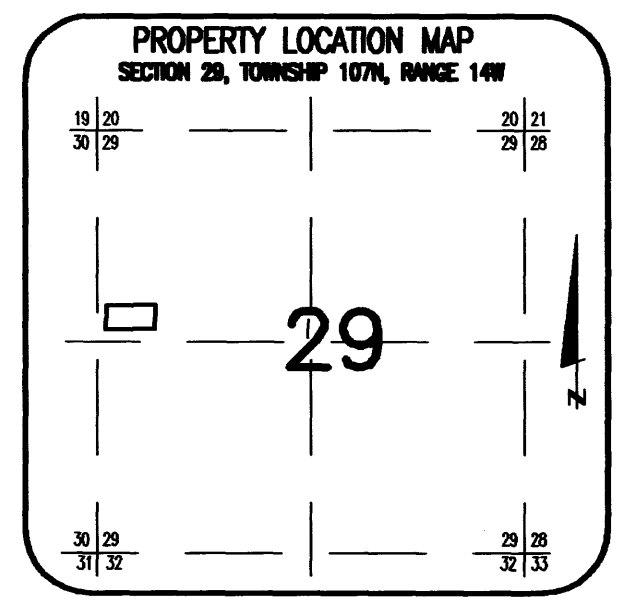

SURVEYOR'S CERTIFICATE

I, James E. Swanson, do hereby certify that the work was undertaken by or reviewed and approved by me for this CIC Plat of COMMON INTEREST COMMUNITY NUMBER 305 A CONDOMINIUM, WEST 19 BUSINESS PLAZA being located upon the following described property:

That part of Lot 1, Block 1, WEST 19 BUSINESS PLAZA, Rochester, Minnesota, which lies easterly of the following described line:

Commencing at the southeast corner of said Lot 1; thence South 87 degrees 08 minutes 49 seconds West, assumed bearing, along the south line thereof, 76.32 feet for the point of beginning of the line to be described; thence North 02 degrees 51 minutes 11 seconds West, 315.93 feet to the north line of said Lot 1 and there terminating.

And the additional real estate described as follows:

That part of Lot 1, Block 1, WEST 19 BUSINESS PLAZA, Rochester, Minnesota, which lies westerly of the following described line:

Commencing at the southeast corner of said Lot 1; thence South 87 degrees 08 minutes 49 seconds West, assumed bearing, along the south line thereof, 76.32 feet for the point of beginning of the line to be described; thence North 02 degrees 51 minutes 11 seconds West, 315.93 feet to the north line of said Lot 1 and there terminating.

fully and accurately depicts all information required by Minnesota Statutes, Section 515B.2-110 (c)

Dated this 26th day of January, 2006.

James E. Swanson
James E. Swanson L.S., Minnesota License No. 11622.

STATE OF MINNESOTA
COUNTY OF OLMPSTED

The foregoing instrument was acknowledged before me this 26th day of January, 2006, by James E. Swanson, a Licensed Land Surveyor.

Beth A. Davis
Notary Public, Dodge County, Minnesota

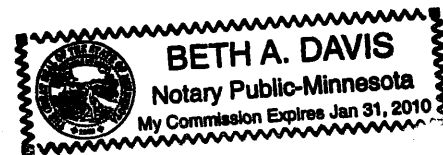

My commission expires on 1-31-2010

PROPERTY RECORDS AND LICENSING

Taxes payable in the year 2006 on the land herein described have been paid, there are no delinquent taxes and transfer has been entered this 2ND day of February, 2006.

W. Mark Krupski, Assistant
Director of Property Records & Licensing

Wendy von Wald
Deputy

COUNTY SURVEYOR

Pursuant to Minnesota Statutes, Chapter 389.09, Subd. 2 this CIC Plat has been reviewed and is approved this 26 day of January, 2006.

Edward P. Kuide
County Surveyor

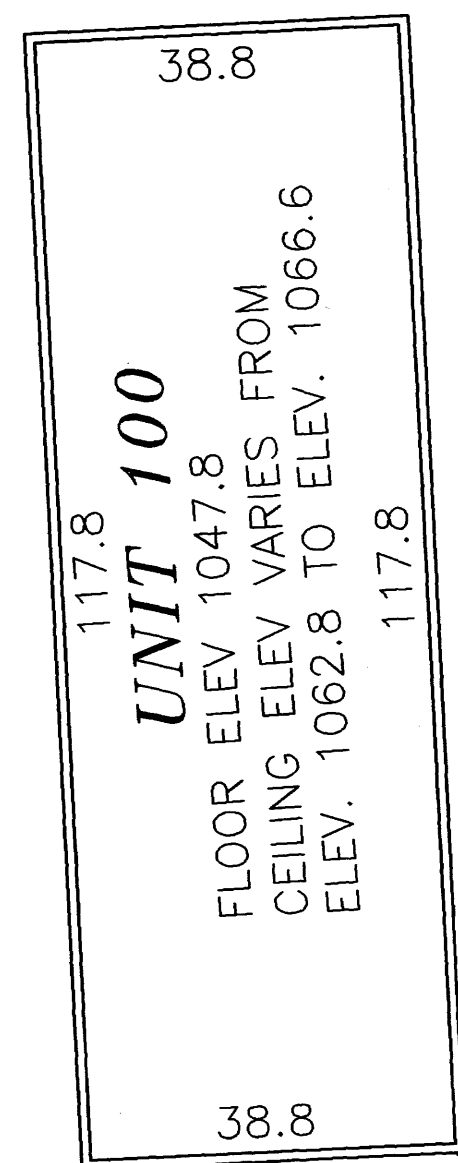

MAIN FLOOR

SCALE 1"=20'

UTILITY EASEMENT (U.E.) defined:
An unobstructed easement for the construction and maintenance of all necessary underground or surface public utilities including rights to conduct drainage and trimming on said easement.

DRAINAGE EASEMENT (D.E.) defined:
An unobstructed easement for the operation and maintenance of waterways, both surface and underground, running over, across, and under said easement.

CONTROLLED ACCESS defined:
Ingress or egress to, from, or across the abutting roadway is restricted by the road authority pursuant to Minnesota State Statute 160.08.

NOTE:

ALL LABELS SHOWN THUS: L.C.E. ARE LIMITED COMMON ELEMENTS.

ALL LABELS SHOWN THUS: C.E. ARE COMMON ELEMENTS.

ALL MONUMENTS SHOWN THUS: ● ARE FOUND 5/8" PIPE UNLESS OTHERWISE NOTED.

PREPARED BY:
McGHEE & BETTS, INC.
CONSULTING ENGINEERS
PLANNERS, LAND SURVEYORS
ROCHESTER, MINNESOTA

1081A